

- 1,5" voice coil Epotex former
- Ferrite magnet
- 91.9 dB sensitivity



Specifications	
Nominal Diameter	165mm (6")
Nominal Impedance	8Ω
Rated Power AES <sup>(1)</sup>	80W
Continuous Program Power <sup>(2)</sup>	160W
Sensitivity @ 1W/1m <sup>(3)</sup>	91.9dB
Voice Coil Diameter	38mm (1,5")
Voice Coil Winding Depth	8mm
Magnetic Gap Depth	6mm
Flux Density	1.05T
Magnet Weight	426g
Net Weight	1.4kg

Thiele & Small Parameters <sup>(4)</sup>			
Re	6.00Ω	Fs	110.0Hz
Qms	3.35	Qes	0.79
Qts	0.64	Mms	9.7g
Cms	216μm/N	Bxl	7.14Tm
Vas	4.6l	Sd	122.7cm <sup>2</sup>
X max <sup>(5)</sup>	+/-1.0mm	X var <sup>(6)</sup>	+/-1.7mm
η <sub>0</sub>	0.73%	Le (1kHz)	0.61mH

Costructive Characteristics	
Magnet	: Ferrite
Basket Material	: Pressed Sheet Steel
Voice Coil Winding Material	: Copper
Voice Coil Former Material	: Epotex
Cone Material	: Paper
Cone Treatment	: No
Surround Material	: Treated Cloth
Dust Dome Material	: Paper Ogive

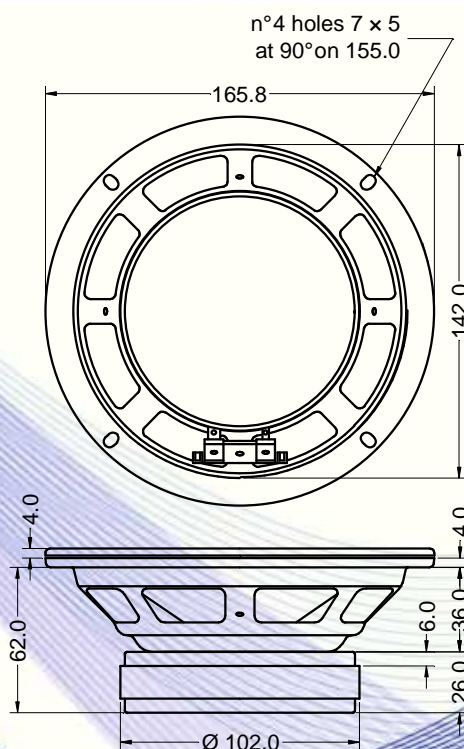

Frequency Response on IEC Baffle (DIN 45575) @ 1W,1m – Free Air Impedance

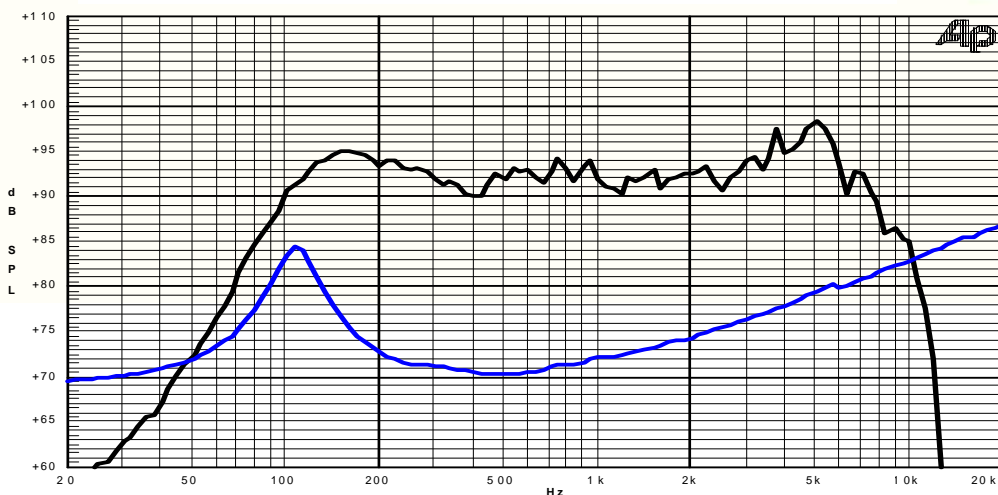

- Note:
- 1 : Rated Power measured with 2 hours test with pink noise signal, 6dB crest factor, loudspeaker mounted on enclosure
  - 2: Power on Continuous Program is defined as 3 dB greater than the Rated Power
  - 3: Calculated by Thiele & Small parameters
  - 4: Thiele & Small parameters measured with laser system without preconditioning test
  - 5: Measured with respect to a THD of 10% using a parameter-based method
  - 6: Value corresponding to a decay of the Force Factor, or Compliance, or both, equal to the 50% of the small signal value.
  - 7: Drawing dimensions: mm
  - 8: The notch around 400Hz on the frequency response is typical of the measurement on IEC baffle