

- 2" voice coil Kapton former
- Ferrite magnet
- Cloth surround with DAR technology
- Front-loaded perforated horn to improve the coupling with the woofer
- Possibility to use different compression drivers
- 98.0 dB sensitivity



Specifications	
Nominal Diameter	320mm (12")
Nominal Impedance	8Ω
Rated Power AES ⁽¹⁾	150W
Continuous Program Power ⁽²⁾	300W
Sensitivity @ 1W/1m ⁽³⁾	98.0dB
Voice Coil Diameter	50mm (2")
Voice Coil Winding Depth	14mm
Magnetic Gap Depth	8mm
Flux Density	1.08T
Magnet Weight	1100g
Net Weight	3.8kg

Thiele & Small Parameters ⁽⁴⁾			
Re	6.20Ω	Fs	63.0Hz
Qms	5.63	Qes	0.56
Qts	0.49	Mms	36.7g
Cms	176μm/N	Bxl	12.53Tm
Vas	70.0l	Sd	530.9cm ²
X max ⁽⁵⁾	+/-4.5mm	X var ⁽⁶⁾	+/-7.0mm
η ₀	2.91%	Le (1kHz)	0.83mH

Costructive Characteristics	
Magnet	: Ferrite
Basket Material	: Aluminium Die-Cast
Voice Coil Winding Material	: Copper
Voice Coil Former Material	: Kapton
Cone Material	: Paper
Cone Treatment	: No
Surround Material	: Treated Cloth
Dust Dome Material	: None

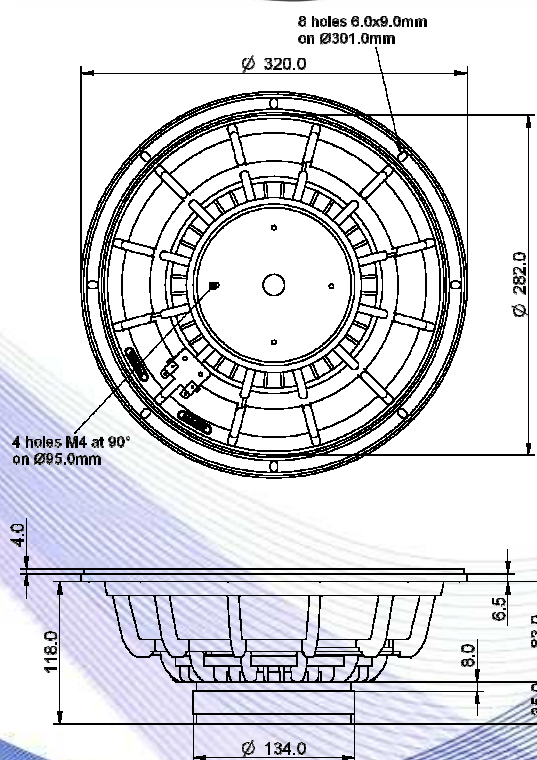

Frequency Response on IEC Baffle (DIN 45575) @ 1W,1m – Free Air Impedance

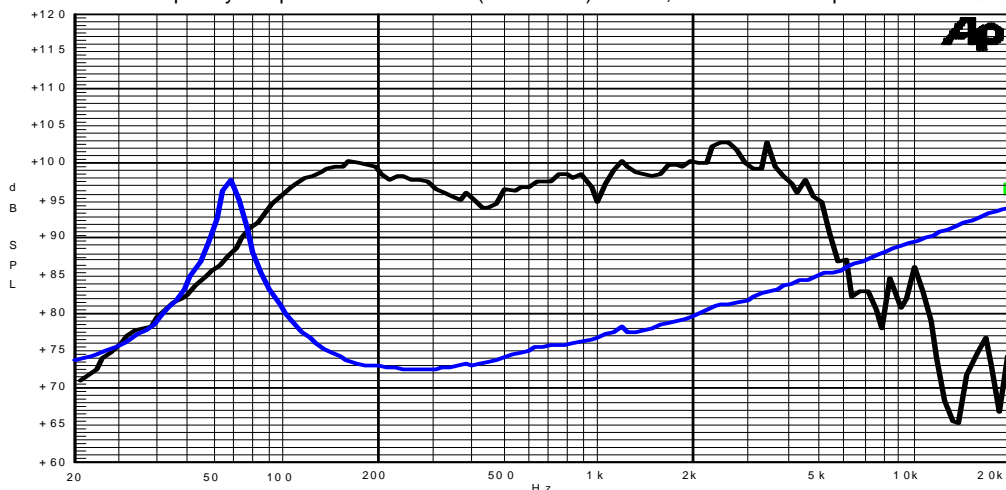

- Note:
- 1 : Rated Power measured with 2 hours test with pink noise signal, 6dB crest factor, loudspeaker mounted on enclosure
 - 2: Power on Continuous Program is defined as 3 dB greater than the Rated Power
 - 3: Calculated by Thiele & Small parameters
 - 4: Thiele & Small parameters measured with laser system without preconditioning test
 - 5: Measured with respect to a THD of 10% using a parameter-based method
 - 6: Value corresponding to a decay of the Force Factor, or Compliance, or both, equal to the 50% of the small signal value.
 - 7: Drawing dimensions: mm
 - 8: The notch around 400Hz on the frequency response is typical of the measurement on IEC baffle