

#### GENERAL CHARACTERISTICS

Nominal Overall Diameter .....	462	mm
Nominal Voice Coil Diameter .....	100	mm
Magnet Weight .....	3300	g
Flux Density.....	1.31	T
Weight.....	12.80	Kg

#### THIELE-SMALL PARAMETERS

Voice Coil DC Resistance .....	$R_E$	3.25	Ω
Resonance Frequency .....	$f_s$	36.9	Hz
Mechanical Q Factor.....	$Q_{MS}$	9.03	
Electrical Q Factor.....	$Q_{ES}$	0.29	
Total Q Factor .....	$Q_{TS}$	0.28	
Mechanical Moving Mass .....	$M_{MS}$	196.2	g
Mechanical Compliance .....	$C_{MS}$	95	μm/N
Force Factor .....	$B \times l$	22.55	Wb/m
Equivalent Acoustic Volume.....	$V_{AS}$	181.9	lt.
Maximum Linear Displacement ....	$X_{MAX}$	+/-6.0	mm
Reference Efficiency .....	$\eta_0$	3.02	%
Diaphragm Area .....	$S_D$	1164.2	cm <sup>2</sup>
Losses Electrical Resistance.....	$R_{ES}$	100.9	Ω
Voice Coil Inductance @ 1kHz .....	$L_E$	1.03	mH

#### CONSTRUCTIVE CHARACTERISTICS

Magnet.....	Ferrite
Voice Coil Winding.....	Copper
Voice Coil Former.....	Fiberglass
Cone .....	Paper
Surround.....	Treated Cloth
Dust Dome .....	Solid Paper
Basket .....	Aluminium Die-Cast

#### ELECTRICAL CHARACTERISTICS

Nominal Impedance.....	8	Ω
Musical Power .....	1400	W
Rated Power* .....	700	W
Sensitivity @ 1 W, 1 m .....	97.9	dB

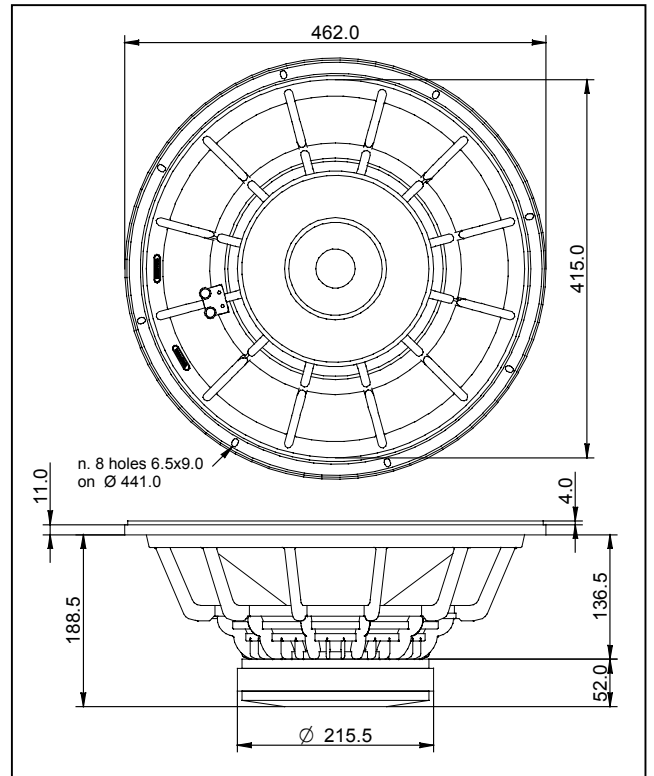

\*rated power measured with 2 hours test with pink noise signal, 6 dB crest factor, loudspeaker mounted on enclosure  
Thiele-Small parameters measured with LASER system

Frequency Response on 150 Litres Vented Box @ 1 W, 1 m - Free Air Impedance

